

# Our locations

- Locations
  - ▲ Servicepoints
  - Dealer
  - Dealer DE
- 1 FHL-Werkzeugmaschinenvertrieb Apolda
  - 2 M.Peters Werkzeugmaschinen Waldshut-Tiengen
  - 3 J+K Jugard + Künstler München
  - 4 Prematech e.K. Obermichelbach
  - 5 Bernd Goll Industrievertretungen Knittlingen
  - 6 PeHa Werkzeugmaschinen Weissenhorn
  - 7 Ralf Brune Maschinenhandel Kierspe
  - 8 Sudler Werkzeugmaschinen Langgöns
  - 9 WS Werkzeugmaschinen Industrievertretung GmbH Wedemark
  - 10 Gläserer + Schmidt GmbH Olching-Geiselbullach

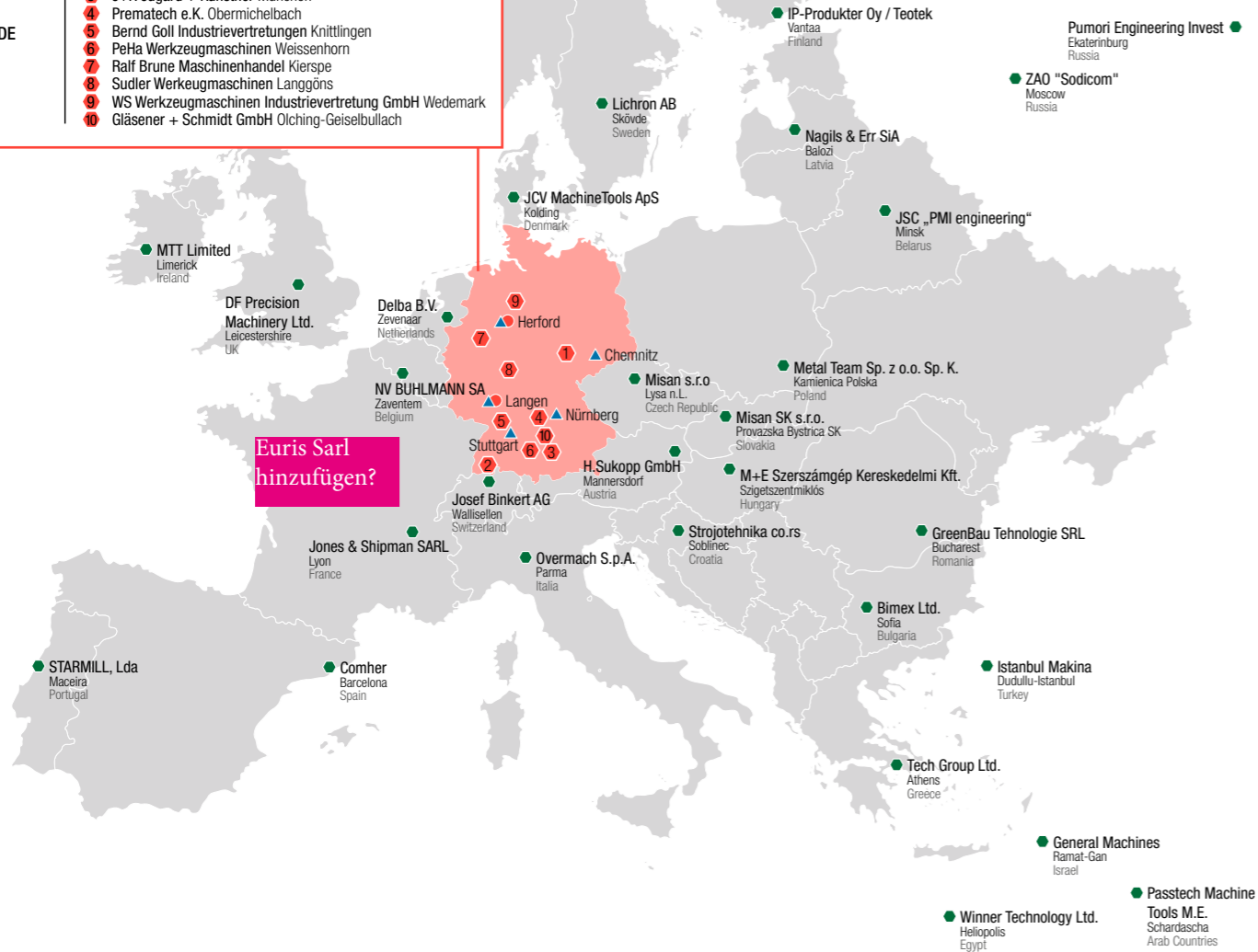

**Okamoto**  
GRIND - X



Okamoto Machine Tool Europe GmbH  
Raiffeisenstraße 7b · 63225 Langen · Germany  
Tel. +49 (0) 6103 - 201 100 · Fax +49 (0) 6103 - 201 1020  
www.okamoto-europe.de · info@okamoto-europe.de

All data contained herein is based on the technical status of the machines at the time of printing. We reserve the right to change any detail via further development. As a result, dimensions, weights, colours, etc. of the delivered machines may vary.  
Printed in April 2021.

# Cylindrical Grinding Machine

UGM

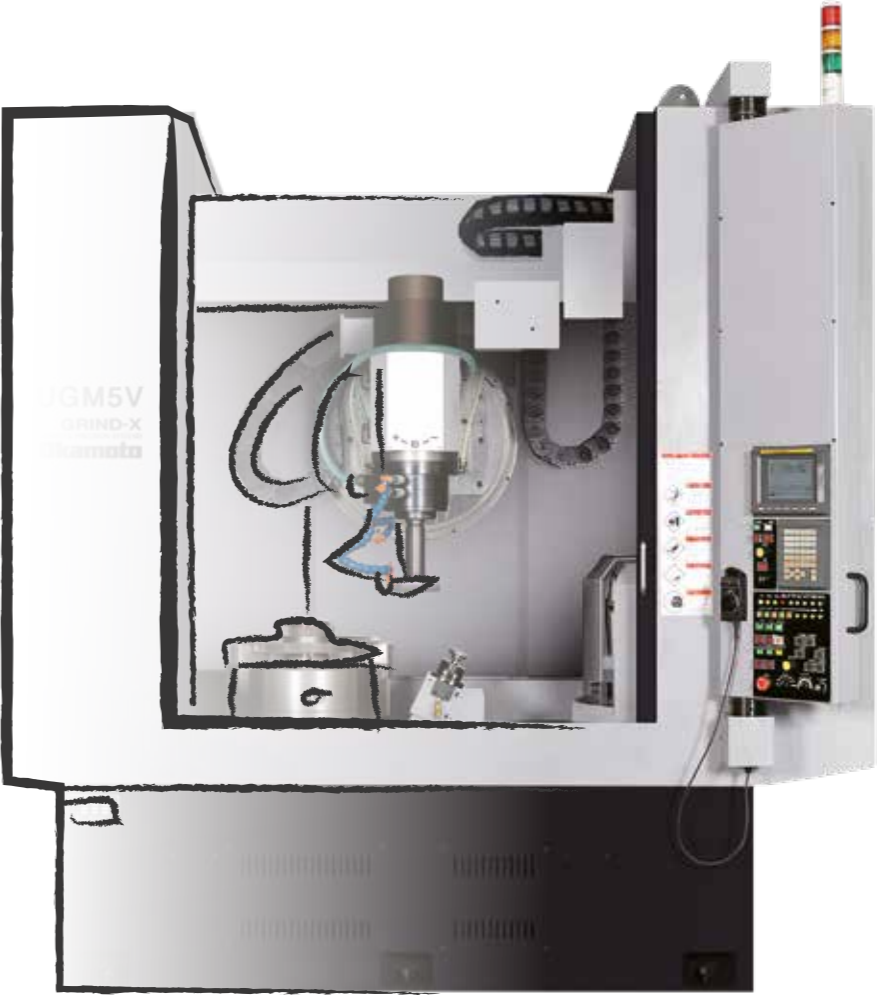

GRIND - X  
OKAMOTO PRECISION SYSTEMS  
**Okamoto**

GRINDING SOLUTIONS

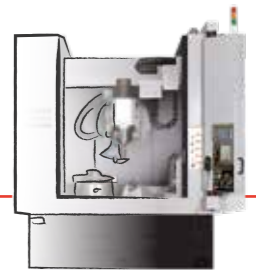

## Precision vertical universal cylindrical grinding machine with B axis

With the introduction of this new universal series of vertical and internal grinding machines, Okamoto combines its extensive know-how in the field of internal and external grinding in an entirely new design.

- CNC universal vertical grinding machine
- Pivoting wheel head (B axis)
- Automatic Tool Changer for 4 wheels
- Roundness 0.9 μm



### ADDITIONAL EQUIPMENT

- 3-jaw chuck 500mm diameter manual
- Wheel mounts / holder with clamping cone BT40
- Coolant system with paper belt filter SBF 60
- Coolant system with magnet separator and temperature controller

Developed on existing Internal Grinding machine and capable of doing larger and heavier work precisely.

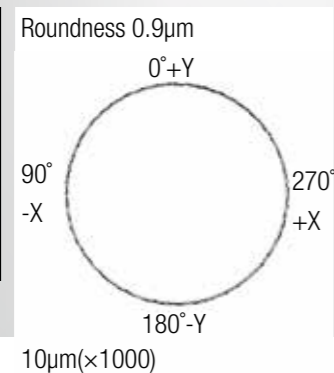
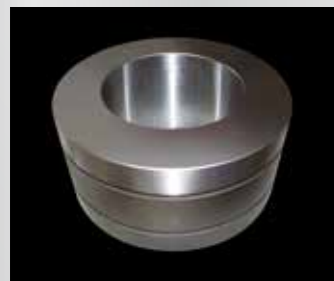

### ATC (AUTO TOOL CHANGER FUNCTION)

Equipped with ATC (Max 4 tool) as standard.



### AUTOMATIC WHEEL HEAD SWIVEL FUNCTION

Using a Curvic Coupling for wheel head swivel, 0 deg. & -30 deg. For Precision positioning.



	Description	Unit	UGM 5V
<b>Capacity</b>	Swing on the table	mm	Ø 550
	Grinding inner diameter	mm	Ø 75-400
	Grinding outer diameter	mm	to Ø 550
	Maximum grinding length	mm	300
	Maximum load (on table)	kg	500
<b>Wheel spindle</b>	Specifications of wheel used	mm	Ø 200 x 40 x 50.8 Ø 50-100 x 50 x 22.5
	Revolution speed	min <sup>-1</sup>	500-8000
	Maximum circumferential speed	m/sec	50
	Taper hole		BT40 two-face contact (without drive key)
<b>Wheel spindle infeed (X-axis)</b>	X-axis maximum travel amount	mm	1100
	Minimum setting unit	mm	Ø 0.0001
	Grinding feed rate	mm/min	0.001 - 20000
<b>Longitudinal wheel feed (Z-axis)</b>	Rapid feed rate (manual, automatic)	mm/min	20000
	Z-axis maximum travel amount	mm	450
	Minimum setting unit	mm	0.0001
<b>Wheel head (B-axis)</b>	Grinding feed rate	mm/min	0.001 - 15000
	Rapid feed rate (manual, automatic)	mm/min	15000
<b>Work spindle</b>	B-axis maximum swivel angle	Degree	0 or 30
	Table size	mm	Ø 500
<b>Hydraulic unit</b>	Revolution speed	min <sup>-1</sup>	10~150
	T slot	mm	18 x 8s lot
	Discharge pressure	MPa	11.0
<b>Motor</b>	Tank capacity	L	60
	For wheel spindle (AC built-in motor)	kW	11 (βi112S/15000)
	Work spindle (AC servomotor)	kW	5.5 (αiS40/4000-B)
	Wheel infeed (AC servomotor)	kW	4.5 (αiS22/4000-B)
	Longitudinal wheel feed (AC servomotor)	kW	5.5 (αiS30/4000-B)
	For driving the ATC (AC servomotor)	kW	0.5 (βiS1/6000-B-B)
	Hydraulic pump	kW	5
	For driving the dresser (option)	W / P/min <sup>-1</sup> (Hz)	60/2/2650/3200 (50/60)
	Grinding coolant injection pump (option)	kW/P	1.1/2
	Dressing coolant injection pump (option)	W/P	250/2
	Pump-up pump (option)	W/P	250/2
	Magnetic separator (option)	W/P	25/2
	Automatic liquid temperature controller (option)	W	max. 1160
Dust collector (option)	W	750	
<b>Installation space</b>	Width x Depth x Height	mm	2650 x 2380 X 3032
<b>Weight</b>		kg	9000
<b>Power supply</b>	Power requirement	V / Hz	200, (three-phase), 50/60 (main unit)
	Power consumption	kVA (main unit)	45
<b>Air pressure requirement</b>	Pressure requirement	MPa	0.5
<b>Noise level</b>	Flow rate requirement	L/min	160 (during air blow 420)
		dB	70-75

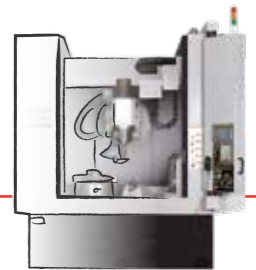

## Precision cylindrical grinding machine with B-axis

Standard software with 10-step grinding program. Software for profile grinding optionally available. Entry of grinding data via touchscreen. Wheel and work spindles driven by Fanuc AC servomotors. A swing down wheel dressing device for internal grinding is included in the standard equipment.

- Double V table slideways
- T-shaped machine bed
- Temperature-stabilized spindles
- Low-maintenance B-axis motor with direct drive
- Directly powered ball screws



### ADDITIONAL EQUIPMENT

- Motor-powered tailstock
- Roll dresser
- Gap Elimination
- Programming software iCAM / EDELAC Win

Allows multiple grinding capabilities and improves productive

### T-FRAME CONSTRUCTION ELIMINATES TABLE BASE OVERHANG

Solid single piece T-Frame casting provides superior rigidity and thermal stability.



### THOROUGH THERMAL EXPANSION MEASURES

Solid piece T-Frame casting and constant over the table coolant allows a more stable control of thermal growth

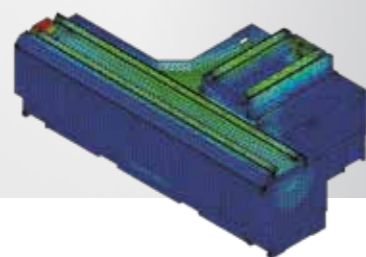

Thermal distribution map for Table and Wheel head slideway

### DOUBLE V TABLE WAYS YIELDS HIGH PRECISION IN STRAIGHTNESS AND PARALLELISM

V-V table way construction reduces grinding pressure and greatly improves straightness accuracy when compared to V-Flat way system.

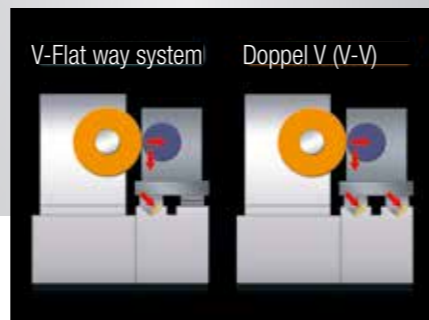

	Description	Unit	UGM 360 NC	UGM 3100 NC
<b>Workhead</b>	Spindle type		High-strength combined live & dead spindle	
	Centre taper	MT	5	
	Through bore	mm	Ø 28	
	Spindle speed	min <sup>-1</sup>	10 ~ 500	
	Swivel angle	Degree	90	
	Swivel angle operator side	Degree	30	
<b>Tailstock</b>	Tailstock sleeve		Taper control type	
	Sleeve stroke	mm	30	
	Taper	MT	4	
<b>Motors</b>	Wheel spindle (AC motor)	kW	11.0/4 (Direct drive)	
	Internal grinding spindle (AC motor)	kW	3.7	
	Workhead Spindle (C-axis/AC motor)	kW	1.8 (βiS12/3000HV)	
	Table feed (Z-axis/AC motor)	kW	4.5 (αiS/4000HV)	
	Wheelhead infeed (X-axis / AC servo motor)	kW	3.0 (αiF12/4000HV)	
	Wheelhead swivel Motor (B-axis / AC servo motor)	kW	5.6 (Direct drive: DiS250/250)	
	Lubricant pump	W/P	3/4	
	Oil temperature controller	W	2800	
	Oil temperature controller pump	W	400/1500W(O.P)	
<b>Grinding wheel</b>	Size (Outside - Ø x B x Inside - Ø)	mm	Ø 510 x 63 (OP80) x Ø 203.2	
	Rotational speed min.	min <sup>-1</sup>	900~3200	
	Max. peripheral wheel speed	m/sec	60	
<b>Feed axis (X-axis)</b>	X-axis stroke	mm	360	
	Min. input increment	mm	0.0001	
	Rapid traverse	mm/min	10000	
<b>Swivel Axis (B-axis)</b>	Swivel angle	Degree	2 Spindle (+0~-180°), 3 Spindle (+0~-240°)	
	Min. input increment	mm	0.0001	
	Rapid traverse	min <sup>-1</sup>	15	
<b>Table (Z-axis)</b>	Z-axis stroke	mm	850	1250
	Swivel angle	Degree	0 ~ 8.5	0 ~ 6.0
	Min. input increment	mm	0.0001	
	Rapid traverse	mm/min	20000	
<b>Power consumption</b>		kVA	33	36
<b>Tank capacity</b>	Lubricant	L	3	
	Coolant	L	80	
<b>Control</b>	Type		FANUC Oi-TF	
	Number of controlled axes		3 (2-axis simultaneously)	
	Coordinates		Polar, Linear, Arc	
<b>Work height</b>	High floor - Centre workpiece	mm	1135	
<b>Space requirement</b>	Width x Depth x Height	mm	2780 x 2750 x 1900	3650 x 2750 x 1900
<b>Total weight net</b>		kg	7000	7900

# High accuracy Universal Grinding Machine.

UGM

Ultra-rigid construction delivers the ultimate in precision, versatility and productivity

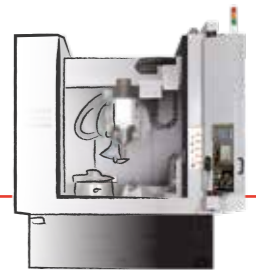

## The UGM Series multiple grinding capability performs Cylindrical, Internal & Face Grinding with one chucking at the highest level of accuracy.

Advanced technology for Universal Grinding compared to the stand alone Cylindrical and Internal Grinders. The combination of a Plain approach OD spindle, Angle approach OD spindle and Internal spindle on a single turret base enables multiple cylindrical, face and internal grinding processes in one chucking. The automatic indexing system enables single chucking of the part to reduce part handling and optimizing throughput and accuracy.

- Proprietary Okamoto conversational software simplifies complicated data input.
- V-V table way construction reduces grinding pressure by one half and greatly improves straightness accuracy when compared to V-Flat way systems.
- Solid single piece T-Frame casting provides superior rigidity and thermal stability.
- High-precision grinding performance is assured through the use of high accuracy positioning direct drive motor for spindle indexing.
- Built-in type high-precision spindle motors are temperature controlled to reduce thermal expansion, minimizing spindle thrust for ultimate high precision.

Horizontal Type  
UGM360NC, UGM3100NC

### ADVANTAGE FOR HORIZONTAL TYPE CONFIGURATION

- Higher efficiency of productivity is achieved with Larger Grinding wheels than Vertical type machine.
- Equipped with independent spindle units for each wheel, which optimizes speed on each unit.
- Built-in type high-precision spindle unit contributes to high-efficiency grinding.
- The same graphics type software is used as seen on the cylindrical grinding machines.



### 3 Machine processes within 1 machine, reduces complete process time dramatically

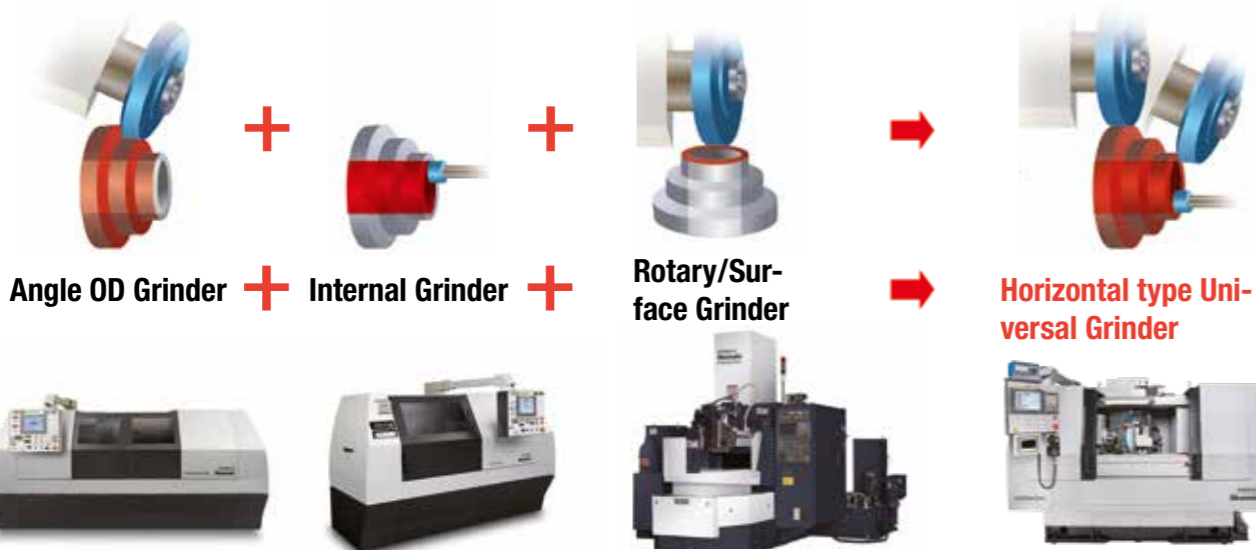

## 3-Spindle Turret Head enables OD, Angle OD/Face and ID grinding for optimum productivity

OD grinding

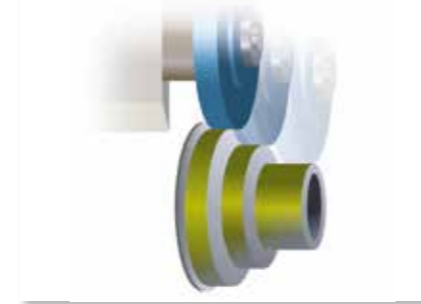

Angle OD/face grinding

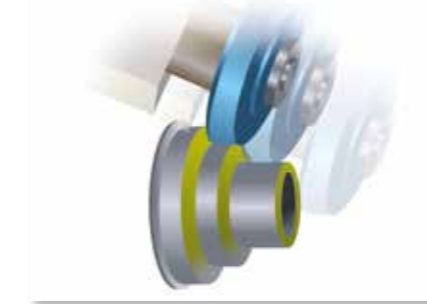

ID grinding

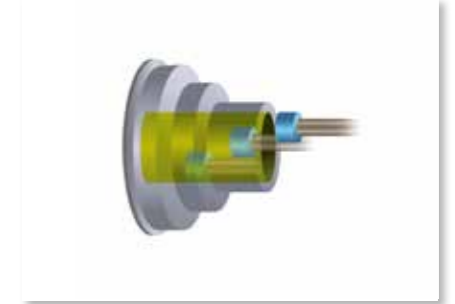

Plain OD spindle (OP)



Angle OD spindle



ID spindle

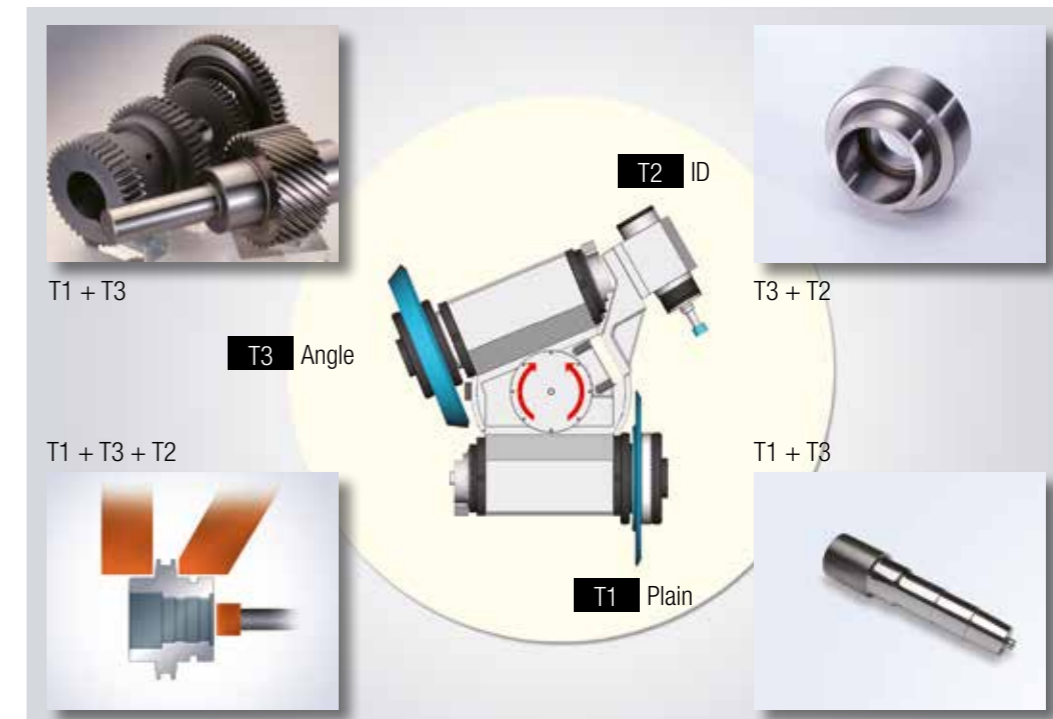

Spindle index by turret. Each spindle can be set to run at an independent speed.

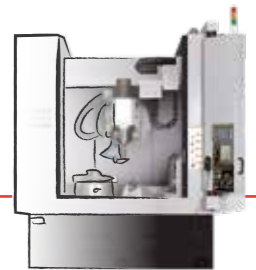

Working range

UGM360NC

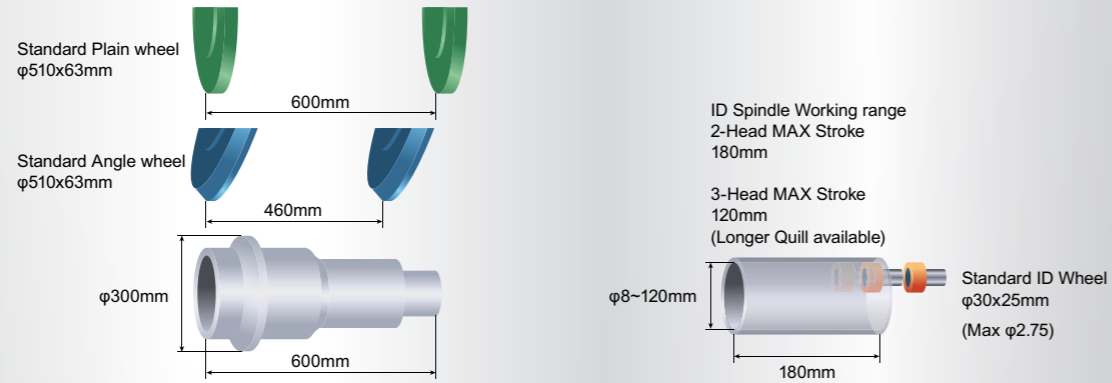

UGM3100NC

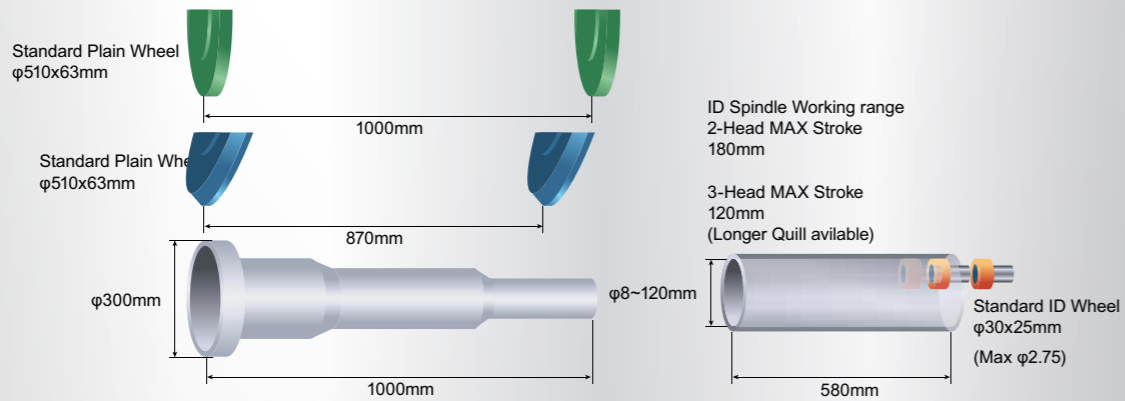

Various spindle layout

T2 + T3

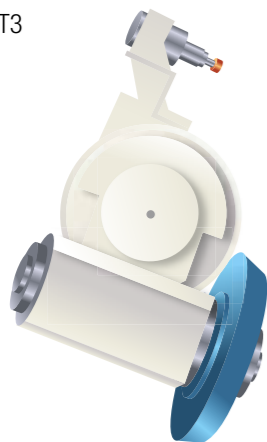

Angle + ID Spindle unit (Standard)

T1 + T2

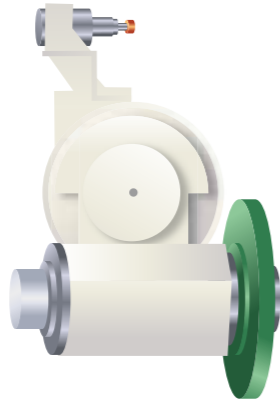

Plain + ID Spindle unit (Option)

T1 + T2 + T3

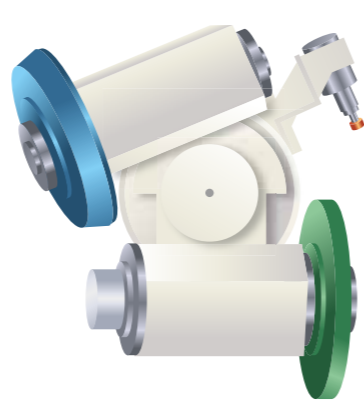

Angle + Plain + ID Spindle unit (Option)

Graphical conversational software supports data input.

Select Dress required spindle unit from T1, T2 & T3, input grinding wheel diameter, width and grit. Software will calculate suggestions for recommended grinding conditions, and dressing condition automatically.

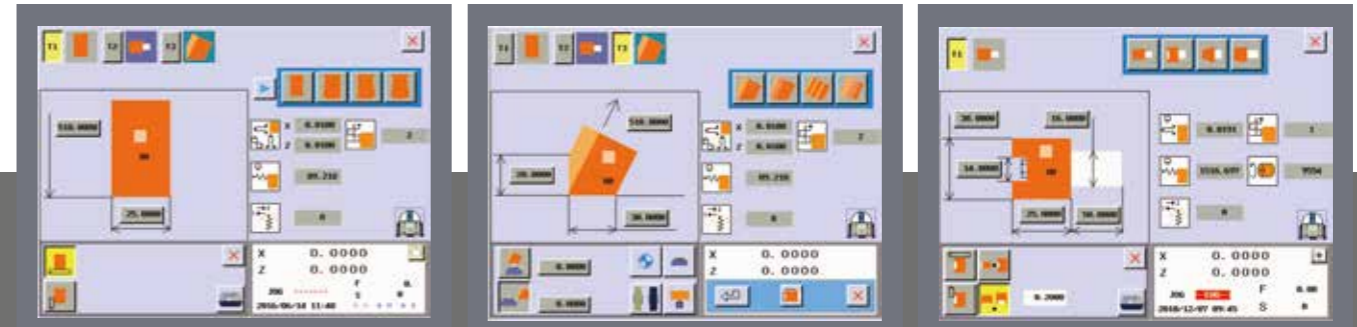

Straight wheel dress screen

- Straight
- Right, left, both shoulder
- Multi-step straight (OP)
- Taper (OP)
- NC forming (OP)

Angle wheel dress screen

- Straight
- Left face-R
- Multi-step straight (OP)
- NC forming (OP)

- Straight
- Face
- Taper (OP)
- Radius form (OP)

Polygon grinding with on-machine measurement (OP)

Polygon grinding

Polygon shape grinding is available by Work spindle axis CNC control (C-axis) (OP)

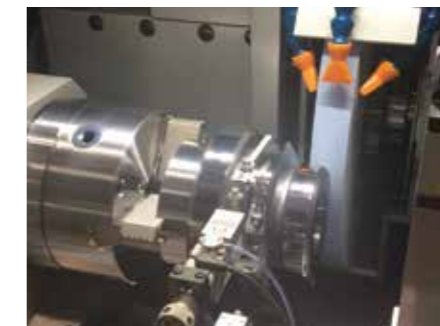

Polygon grinding

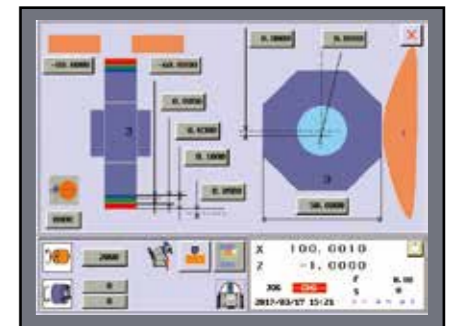

Polygon grinding software screen

On-machine measurement (OP)

Shoulder Locator, In-process gauging are available as option ideal for mass production work. Measuring takes place in process to eliminate set up error.



In-process gauging device

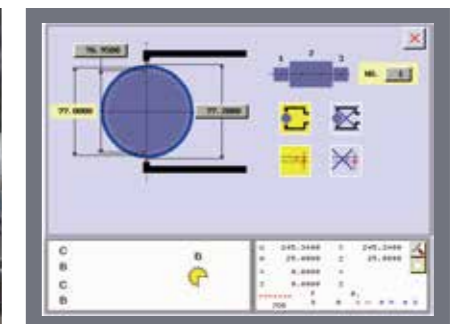

Measurement software screen

# Cylindrical Grinding Machine



Achieving high accurate grinding with multi-process and high rigidity.

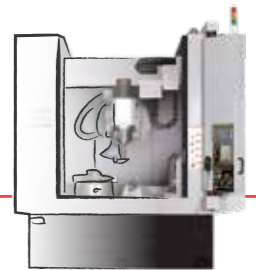

## Suitable for larger size workpieces which are more difficult to chuck horizontally

The Universal style machine has advantage for both productivity, and especially accuracy for perpendicularity, concentricity with great reduction of set up time.

- Okamoto's exclusive G.U.I. software with its easy-to-read icon graphical controller
- Scale feedback is standard for wheel infeed and table longitudinal axis
- Max of 4 different grinding wheel with Auto Tool Changer
- Precise index system with curvic coupling system for spindle swivel to 0° or -30° (2-position)
- Compact and small footprint design
- Built-in type high-precision spindle unit suitable for high accuracy work
- Equipped Rotary Dresser Unit capable of dressing Small to large size wheels

Vertical Type  
UGM5V



## ADVANTAGE FOR VERTICAL TYPE GRINDING MACHINE

- Suitable for long size work pieces which may be difficult to keep straight
- Suitable for heavier workpieces (i.e. large gear, casing, etc.)
- Max 4 ATC available for doing universal grinding

## Dress form software screen

Graphical software with touch and teach capabilities allows for easier data input

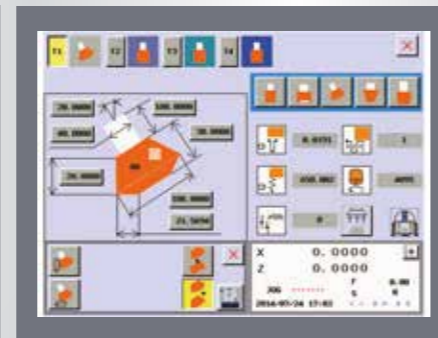
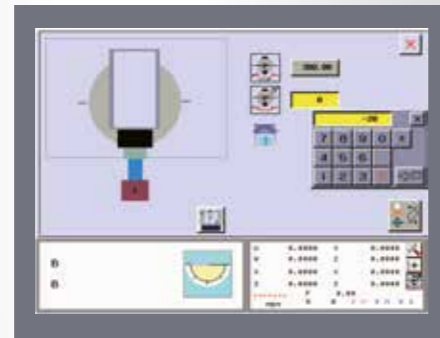

Dress form screen for Internal grinding wheel

Grinding spindle swivel screen

Angle wheel dress screen

Angle grinding



Internal grinding

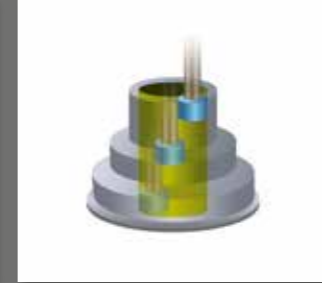

Cylindrical (OD) grinding

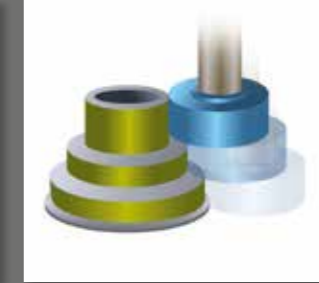

Face grinding



Angle type grinding wheel



Internal grinding wheel



Straight grinding wheel



Grinding wheels are changed by the ATC, variety of grinding wheels can be equipped.

## Saving multiple set ups with just One-chucking

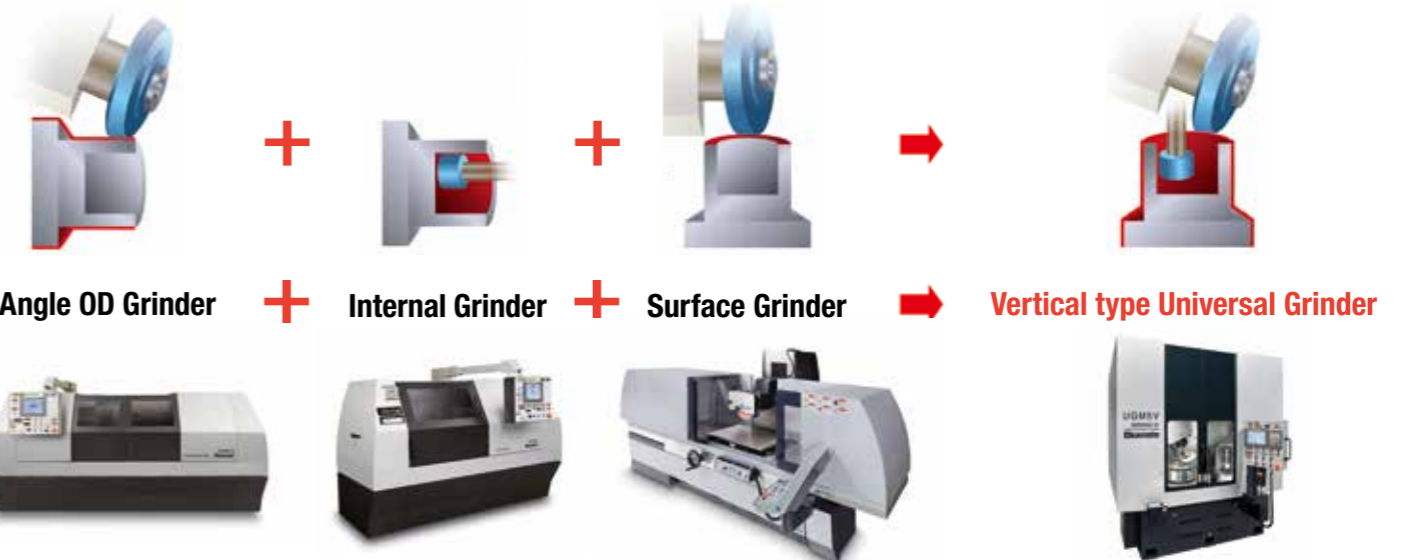

# Choose horizontal type or vertical type by workpiece



## Software

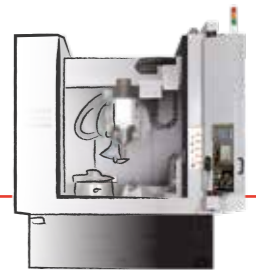

### Between centers type workpiece

Only available on the horizontal type machine



Horizontal

### Over 12" size diameter



Vertical

### Longer size of workpieces

Steady rest also available for long & heavy workpieces



Horizontal

### Taper grinding

Horizontal type machine is capable of swiveling either the work spindle or table for taper grinding.

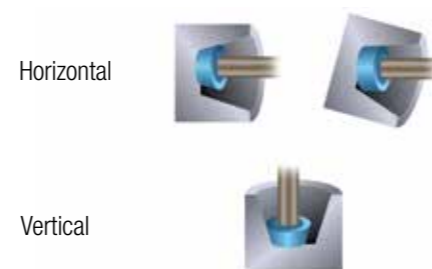

Horizontal

Vertical

### Various type of chucks are available

Gauging, locator device and various type of chuck



Horizontal

### Suitable for mass production workpiece

Max. 20" OD Grinding wheel size available. Large size of grinding wheel helps with improved productivity.



Vertical Horizontal

## Conversational type software

Okamoto's exclusive G.U.I. software with its easy-to-read icon graphics enables operator's to easily input complicated grinding programs.

### Touch Screen control

Graphical type software with easy-to-read icon helps complete programs for complicated workpieces

### Grinding process and dress data have auto edit function

Input grinding wheel grit, wheel width and final sizing value, and allow the machine to provide a suitable grinding process program as well as dress program.



### File management

15 Programs for UGM-NC series, 21 programs for UGM-V series can be stored internally.



## UGM-NC Series

### Okamoto's exclusive G.U.I. software

The same software as standard cylindrical & internal grinder. Easy to learn universal machine if the customer is already using cylindrical & internal machines.



### Main Screen

Setup of 10 steps max. Simplify grinding process from complex form using separate process on OD, ID & angle wheels

Entry for grinding process  
Wheel form display

Select grinding wheel / Dress condition set up screen

Select grinding mode / Grinding condition set up screen

Auto calculation software for setting up grinding process data & dress data

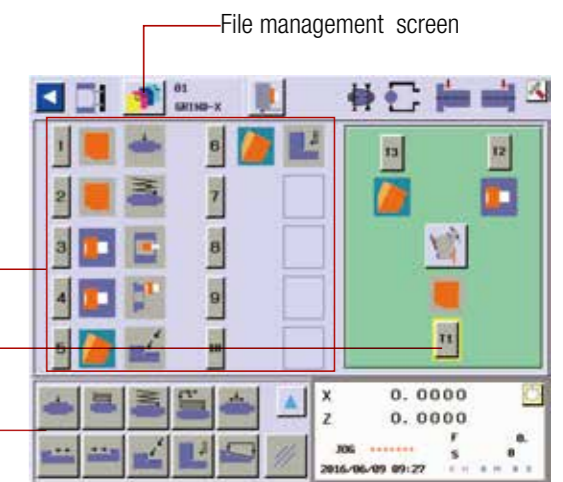

## UGM-V Series

### Grinding condition set up screen (common)

Auto calculation for grinding condition with our extensive experience in grinding



### Grinding date set up screen

Using the same style software allows it to easily manage conventional grinding jobs and Multiple feature grinding jobs



### Main screen

Set up grinding process for each grinding wheel. Max 4-different grinding wheels in one set up



# Cylindrical grinding machine

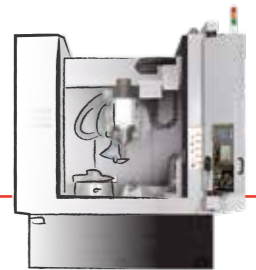

## Accessories

Standard		Optional	
UGM NC	UGM 5V		
Infeed axis closed loop control	Conversational type graphic software	Items	Various type coolant system
Angle type spindle	Spindle swivel function		Oil mist collector
Internal grinding spindle(10,000 - 45,000min <sup>-1</sup> )	ATC (4 pcs max.)		Hood for mist collector
Plan grinding spindle	Rotary dresser unit		Cleaning spray nozzle
Standard internal grinding wheel	Vertical, table longitudinal scale feed back system	Various types of chucks	3-Jaw scroll chuck
Wheel adaptor	Spindle cooling unit		Magnetic chuck
Carbide tip center 2 pcs	LED work light	Various types of Dressing units	Rotary dresser unit
Circuit breaker	3-color signal tower		Radius dresser unit
Table enclosure	Table enclosure		Angle dresser unit
Work light	Leveling bolts and plates	Option for Table mounting unit	Various types of tailstock units
Dress coolant	Necessary tools with tool box		2-point steady rest
Table top coolant supply for cleaning & thermal control			3-point steady rest
Locator device			Work rest
Table swivel angle measurement device		Various types of Grinding wheels	Drive dog set ( 1/4 - 3", 6 pcs)
MPG handle box			Automatic work driver
Grinding Spindle speed meter			Wheel balancer unit, BW-5
Work spindle speed meter			Micro balancer, MB-4
Graphical type conversational software		Measurement	Spare wheel adaptor
Leveling bolts with plate			Gauge sizing device
Necessary tools with box		Others	Gap eliminate sensor system
Primary transformer (Machine operate 400V 3-phase)			Specific color painting for the machine
NC controller unit, FANUC Oi-MF			Table longitudinal scale feed back system
Manual type tail stock unit (only UGM-12.40NC machine)			Special dress cycle software
			EDELAC Win

## 3-Spindle Turret Head enables OD, Angle OD/Face and ID grinding for optimum productivity

2-point steady rest



Work rest



Drive dog set



Automatic work driver



Table swivel measurement device



Coolant tank



Gauge sizing device



Locator device



## Machine overview UGM NC

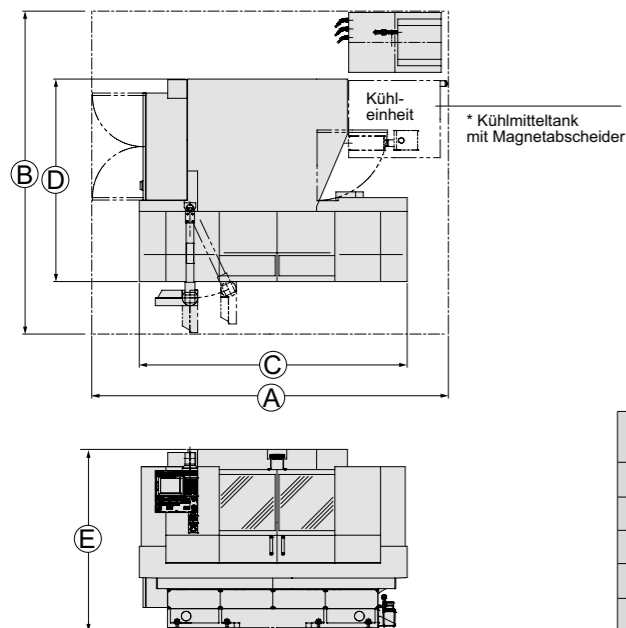

## Machine overview UGM 5V

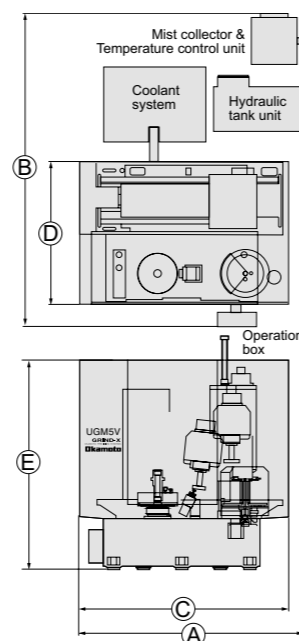

mm	UGM360NC	UGM3100NC	UGM5V
A	3800	4200	2860
B	3500	3500	3938
C	2780	3650	2650
D	2100	2100	1813
E	1900	1900	2660

## Example for automatic loading system

Automatic loading system by robot



IGM & OGM Loading system

